

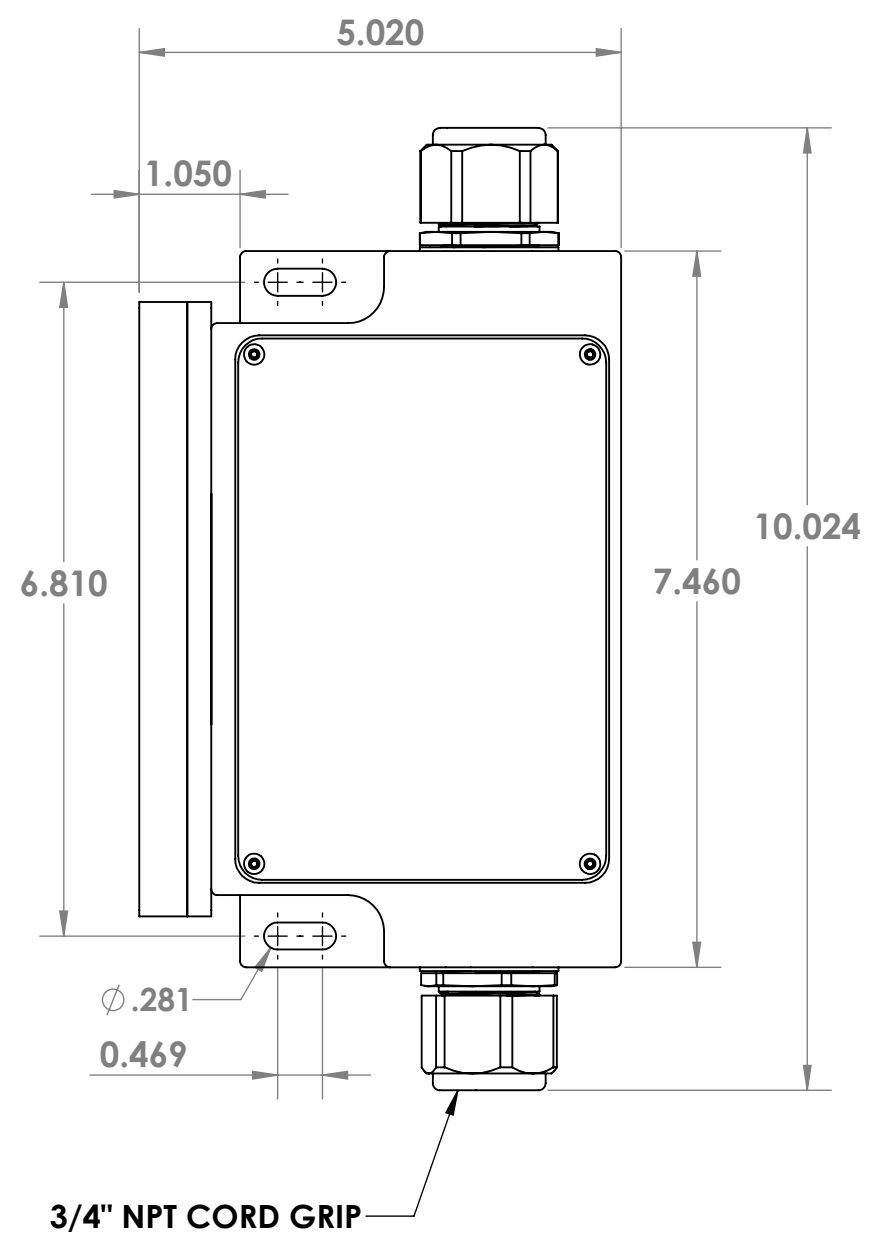

MOUNTING DIMENSIONS

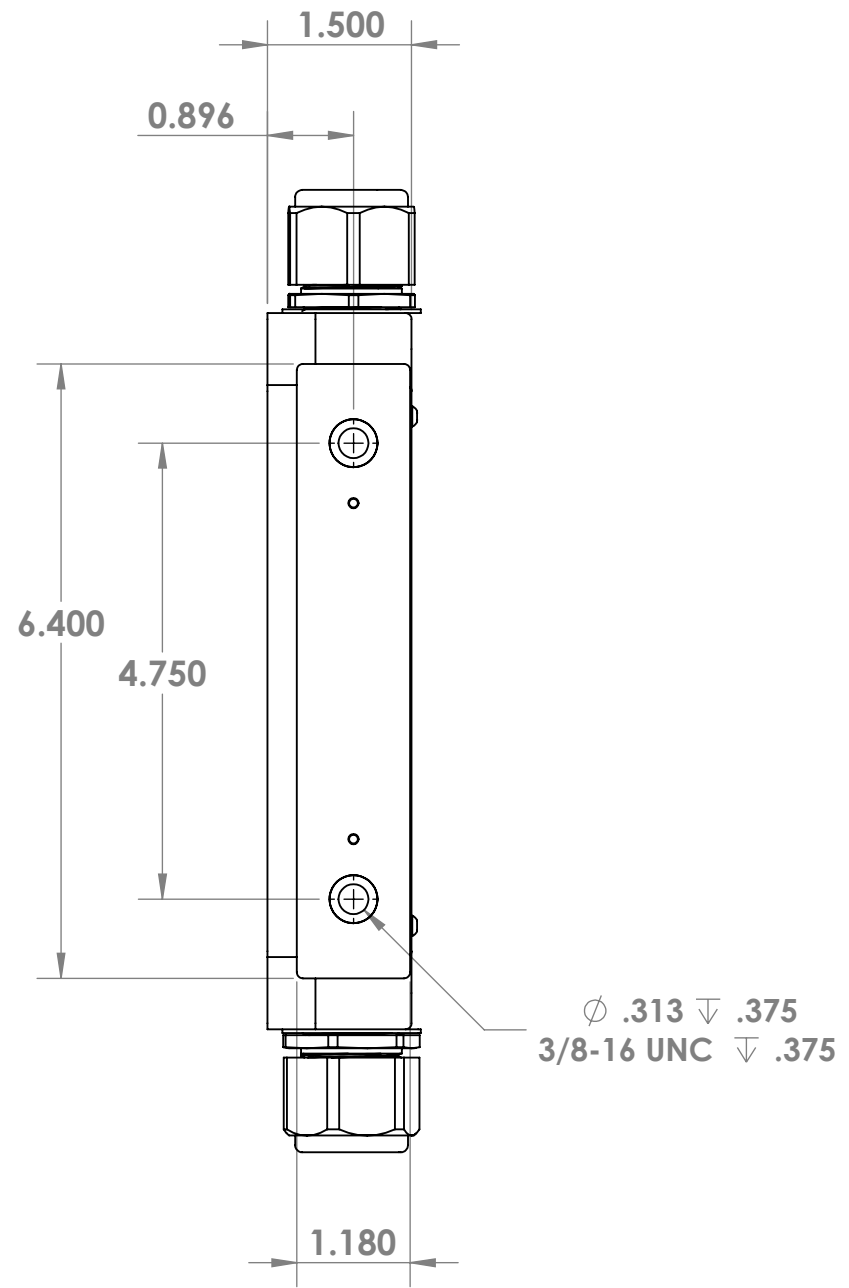

UNLESS OTHERWISE SPECIFIED:		NAME	DATE	 MARIETTA NONDESTRUCTIVE TESTING 530 COMMERCE PARK DRIVE MARIETTA, GA 30060 (770) 528-9000
DIMENSIONS ARE IN INCHES TOLERANCES: FRACTIONAL: \pm 1/16 ANGULAR: \pm 2 Degrees TWO PLACE DECIMAL: \pm .02 THREE PLACE DECIMAL: \pm .005 DECIMAL: \pm .005 SEE BACK FOR SIGNOFF SHEET IF APPLICABLE MATERIAL		DRAWN	L. CUBERO	
FINISH		CHECKED		
NONE		ENG APPR.		
DO NOT SCALE DRAWING		CAGE NUMBER: 1QPN7		TITLE:
		PROPRIETARY AND CONFIDENTIAL		1.50 CDRH INTERLOCK PIN SWITCH
		THE INFORMATION CONTAINED IN THIS DRAWING IS THE SOLE PROPERTY OF MARIETTA NONDESTRUCTIVE TESTING. ANY REPRODUCTION IN PART OR AS A WHOLE WITHOUT THE WRITTEN PERMISSION OF MARIETTA NONDESTRUCTIVE TESTING IS PROHIBITED.		SIZE DWG. NO. REV
				B CDRH150A000000SD
		SCALE: 1:2 WEIGHT: 2.3 lb		SHEET 1 OF 1