



El Toro Rojo



## LS-50

Production & Lab UT Scanner

Marietta NDT manufactured LS-50 UT Scanners are designed and produced in Marietta, Georgia under ISO 9001 and Quality standards. The Product Designer proudly states that this system is robust with a very heavy duty steel frame to help provide the stability to produce the best inspection results. The Mic 6 Tooling plate top surface will provide a stable foundation for repeatability and accuracy of your UT Inspection system for the long-term.

It's more than just a lab scanner. Well suited for production or lab environments – part types for inspection could include: drive shafts, gears, rectangular plates, complex shapes, and composites to name a few.

### Application and Usage Ideas to Consider

- Consider the instrument, probes and software for the inspection
- Move from hand scrubbing to an automated, repeatable inspection
- Decide how to develop a fixture to hold the inspection items
- Fork Lift Movable
- Work with your sales team on complex part shapes
- One Year Warranty on Parts and Labor



# LS-50

## Immersion Tank System

### Dimensions, Weights & Measurements

**Internal Tank Size**

26" Wide x 26" Long x 19" Deep

**Turntable - Unidirectional (Optional)**

13" Diameter – Raised from tank bottom by 5 inches when installed

**Machine Travel**

16" X, 16" Y, 16" Z

**External Dimensions**

Height 76" x Width 31 1/2" x Depth 37 1/2"

**Estimated Overall Weight**

600 lbs

**Swivel/Gimbal**

Manual Swivel = +/- 180°

Manual Gimbal = +/- 90°

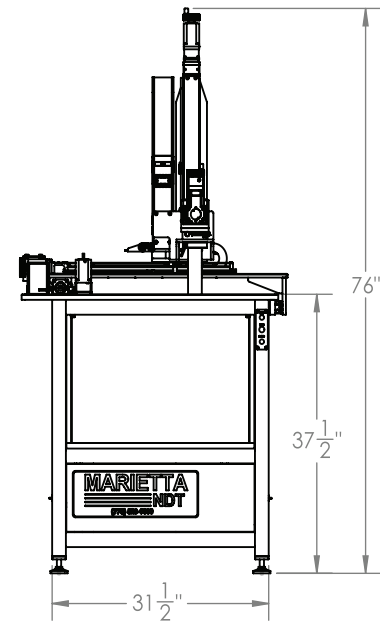

### Standard Features and Requirements

- Heavy Duty Steel Frame Design
- Pallet Jack Movable
- Heavy Acrylic Tank allows for easy viewing and durability
- Mic 6 Tooling plate surface top – casted and machined for a Flat Surface
- Leveling feet and weight mean it will not need to be anchored
- Manual Swivel/Lock
- Tablet Computer provided to operate X, Y, & Z-Axis manipulation
- Ethernet and Serial port connections to the system for communications
- Pump and Filter integrated to clean particulates
- Garden Hose connector provided to easily drain the water
- All parts in or touching the water are Stainless Steel or Bronze for durability
- Flexible to integrate a wide variety of UT instruments and software
- Color: Ruby Red
- Power Requirements: 120 VAC

### Options

- Stainless Steel Tank
- UV light – Cuts down on algae and water changes
- Uni-directional Rotary Turn table – 50lbs Capacity
- Motorized Gimbal/Motorized Swivel
- Heavier parts are possible

